



Instruction book

for

MC860H



Shenzhen Xinlichuan Electric Co.,Ltd.

Add: Area B,Floor 8, Block20 , Guang Qian Industrial Zone ,
No.3 Long Zhu Road,Nanshan District,Shen Zhen,Guang Dong,China

High Performance Digital Stepper Driver

18-80VAC / 7.2A

CATALOG

- ◆ Introduction..... 2
- ◆ Features.....2
- ◆ Applications.....2
- 2. Specifications..... 2
 - ◆ Electrical Specifications (Tj = 25°C/77°F)..... 2
 - ◆ Operating Environment..... 2
 - ◆ Installation specifications (unit: mm [inch])..... 3
 - ◆ Elimination of Heat..... 3
- 3. External terminal instructions..... 3
 - ◆ Control Signal Connector..... 3
 - ◆ Main Circuit Connector..... 3
- 4. Control Signal Connector Interface..... 4
 - ◆ Typical Connection..... 4
 - ◆ Sequence Chart of Control Signals..... 5
- 5. Connecting the Motor.....5
 - ◆ Connections to 4-lead Motors..... 5
 - ◆ Connections to 8-lead Motors..... 5
- 6. Power Supply Selection..... 6
 - ◆ Regulated or Unregulated Power Supply..... 6
 - ◆ Multiple Drivers..... 6
 - ◆ Selecting Supply Voltage..... 6

- 7. Selecting Microstep Resolution and Output Current..... 6
 - ◆ Microstep Resolution Selection..... 6
 - ◆ Current Settings..... 7
 - ◆ Standstill current setting..... 7
- 8. Wiring Notes..... 7
- 9. Protection Functions..... 8
 - ◆ Over-current Protection..... 8
 - ◆ Over-voltage Protection..... 8
 - ◆ Hase Error Protection..... 8
- 10. Frequently Asked Questions..... 8

1. Introduction

◆ Introduction

The MC860H is a high performance microstepping driver based on pure-sinusoidal current control technology. Owing to the above technology and the self-adjustment technology (self-adjust current control parameters) according to different motors, the driven motors can run with smaller noise, lower heating, smoother movement and have better performances at higher speed than most of the drivers in the markets.

It is suitable for driving 2-phase and 4-phase hybrid stepping motors.

◆ Features

- Supply voltage up to 80VAC or +110VDC;
- Output current programmable, from 2.4A to 7.2A;
- Pulse input frequency 300kHz;
- 16 selectable resolutions up to 51,200 steps/rev;
- TTL compatible and optically isolated input;
- Pure-sinusoidal current control technology;
- Self-adjustment technology;
- Support PUL/DIR;
- Short-voltage, over-voltage, over-current protections;
- Automatic idle-current reduction.

◆ Applications

Suitable for a wide range of stepping motors, from NEMA size 17 to 43. It can be used in various kinds of machines, such as X-Y tables, labeling machines, laser cutters, engraving machines, pick-place devices, and so on. Particularly adapt to the applications desired with low noise, low heating, high speed performance.

2. Specifications

◆ Electrical Specifications (T_j = 25°C/77°F)

Parameters	Min	Typical	Max
Output current	2.4A		47.2A
Supply voltage	+24VDC	+48VDC	+90VDC
	18VAC	36VAC	80VAC
Logic signal current	7mA	10 mA	16 mA
Pulse input frequency	0		300 kHz
Isolation resistance	500 M Ω		

◆ Operating Environment

Environment	Avoid dust, oil fog and corrosive gases
Ambient Temperature	0°C — 50°C
Humidity	40%RH — 90%RH
Operating Temperature	70°C Max
Vibration	5.9m/s ² Max
Storage Temperature	-20°C — 65°C

◆ Installation specifications (unit: mm [inch])

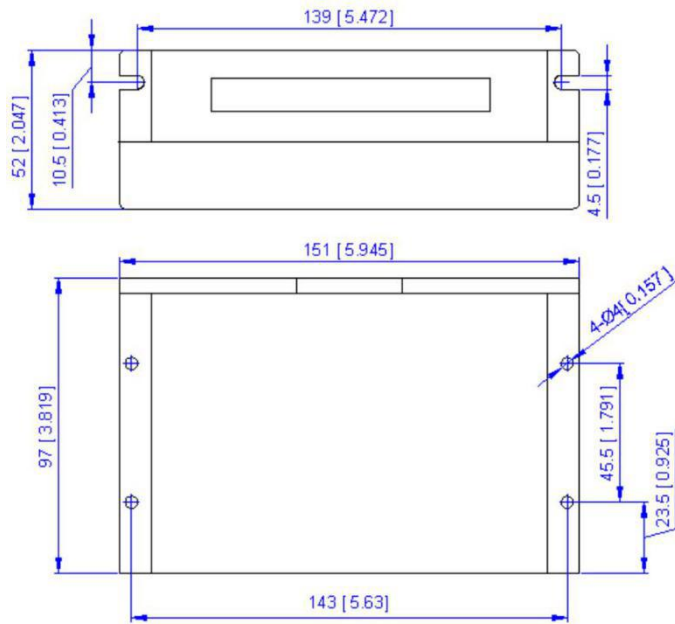

Figure 1: Installation specifications

◆ Elimination of Heat

- Driver's reliable working temperature should be $<70^{\circ}\text{C}$ (158°F), and motor working temperature should be $<80^{\circ}\text{C}$ (176°F);
- It is recommended to use automatic idle-current mode, namely current automatically reduce to 60% when motor stops, so as to reduce driver heating and motor heating;
- It is recommended to mount the driver vertically to maximize heat sink area. Use forced cooling method to cool the system if necessary.

3. External terminal instructions

◆ Control Signal Connector

Pin Function	Details
PUL+	Pulse signal: In single pulse (pulse/direction) mode, this input represents pulse signal, each rising or falling edge active; 4-5V when PUL-HIGH, 0-0.5V when PUL-LOW. For reliable response, pulse width should be longer than $1.5\ \mu\text{s}$. Series connect resistors for current-limiting when +12V or +24V used. The same as DIR and ENA signals.
PUL-	
DIR+	DIR signal: In single-pulse mode, this signal has low/high voltage levels, representing two directions of motor rotation; For reliable motion response, DIR signal should be ahead of PUL signal by $5\ \mu\text{s}$ at least. 4-5V when DIR-HIGH, 0-0.5V when DIR-LOW. Please note that rotation direction is also related to motor-driver wiring match. Exchanging the connection of two wires for a coil to the driver will reverse motion direction.
DIR-	
ENA+	Enable signal: This signal is used for enabling/disabling the driver. High level (NPN control signal, PNP and Differential control signals are on the contrary, namely Low level for enabling.) for enabling the driver and low level for disabling the driver. Usually left UNCONNECTED (ENABLED).
ENA-	

◆ Main Circuit Connector

Pin Function	Details
+V	Power supply, 24~90 VDC, 18~80VAC, Including voltage fluctuation and EMF voltage.
GND	Power Ground.
A+, A-	Motor Phase A
B+, B-	Motor Phase B

4. Control Signal Connector Interface

The MC860H can accept differential and single-ended inputs (including open-collector and PNP output). The MC860H has 3 optically isolated logic inputs which are located on connector P1 to accept line driver control signals. These inputs are isolated to minimize or eliminate electrical noises coupled onto the drive control signals. Recommend use line driver control signals to increase noise immunity of the driver in interference environments. In the following figures, connections to open-collector and PNP signals are illustrated.

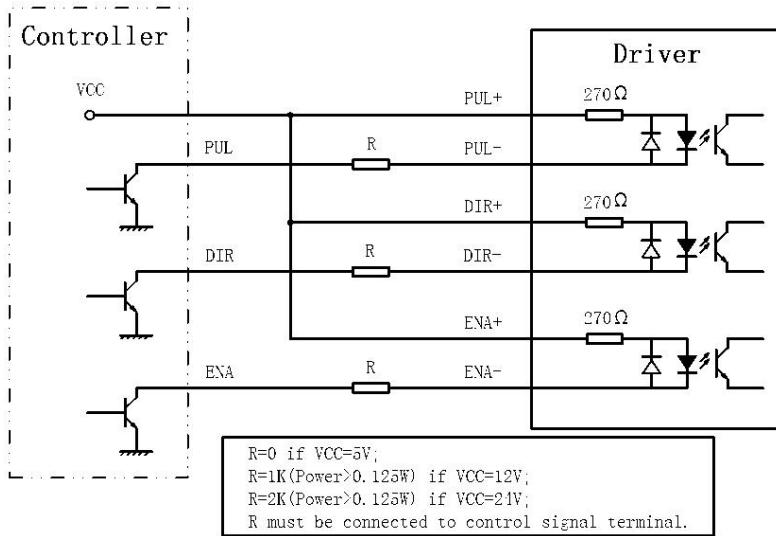

Figure 2: Connections to open-collector signal (common-anode)

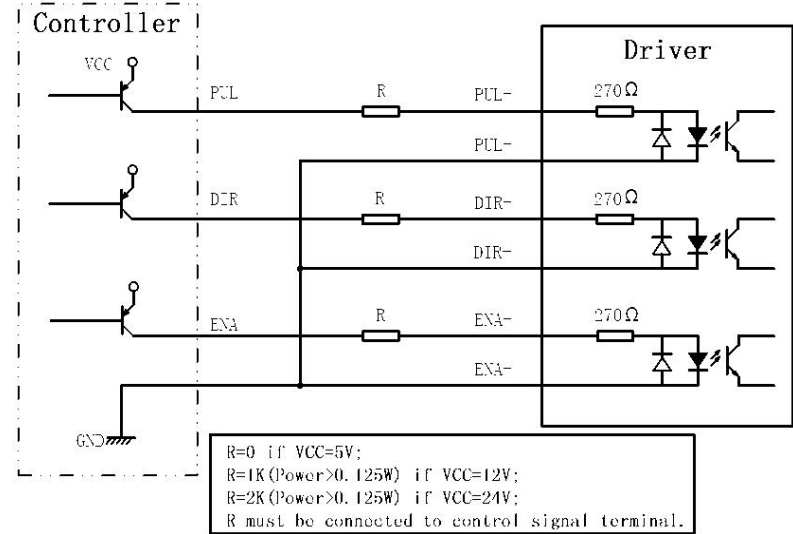

Figure 3: Connection to PNP signal (common-cathode)

◆ Typical Connection

A complete stepping system should include stepping motor, stepping driver, power supply and controller (pulse generator). A typical connection is shown as figure 4.

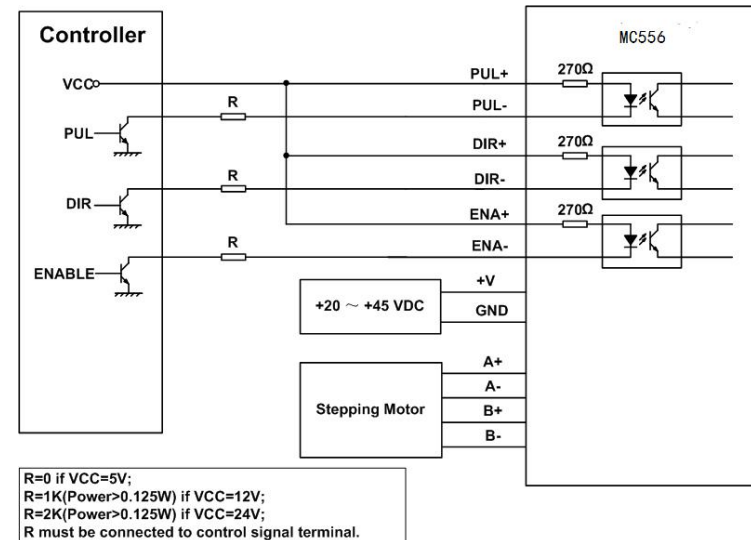

Figure 4: Typical connection

◆ Sequence Chart of Control Signals

In order to avoid some fault operations and deviations, PUL, DIR and ENA should abide by some rules, shown as following diagram:

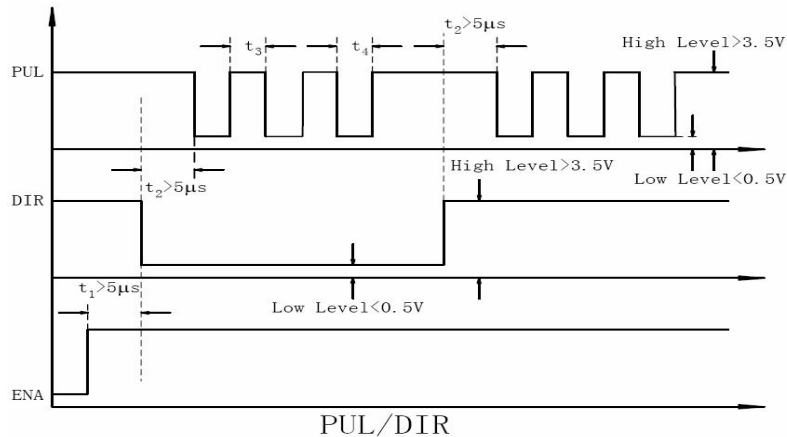

Figure 5: Sequence chart of control signals

Remark:

- t_1 : ENA must be ahead of DIR by at least 5 ms. Usually, ENA+ and ENA- are NC (not connected). See “Connector P1 Configurations” for more information.
- t_2 : DIR must be ahead of PUL effective edge by 5ms to ensure correct direction;
- t_3 : Pulse width not less than 1.5ms;
- t_4 : Low level width not less than 1.5ms.

5. Connecting the Motor

The MC860H can drive any 2-phase and 4-phase hybrid stepping motors.

◆ Connections to 4-lead Motors

4 lead motors are the least flexible but easiest to wire. Speed and torque will depend on winding inductance. In setting the driver output current, multiply the specified phase current by 1.4 to determine the peak output current.

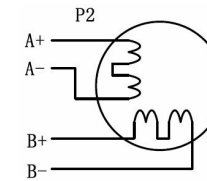

Figure 6: 4-lead Motor Connections

◆ Connections to 8-lead Motors

8 lead motors offer a high degree of flexibility to the system designer in that they may be connected in series or parallel, thus satisfying a wide range of applications.

• Series Connections

A series motor configuration would typically be used in applications where a higher torque at lower speeds is required. Because this configuration has the most inductance, the performance will start to degrade at higher speeds. In series mode, the motors should also be run at only 70% of their rated current to prevent over heating.

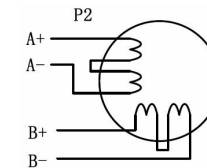

Figure 7: 8-lead motor series connections

6. Power Supply Selection

The MC860H can match medium and small size stepping motors (from NEMA frame size 17 to 34) made by Lichuan or other motor manufactures around the world. To achieve good driving performances, it is important to select supply voltage and output current properly. Generally speaking, supply voltage determines the high speed performance of the motor, while output current determines the output torque of the driven motor (particularly at lower speed). Higher supply voltage will allow higher motor speed to be achieved, at the price of more noise and heating. If the motion speed requirement is low, it's better to use lower supply voltage to decrease noise, heating and improve reliability.

◆ Regulated or Unregulated Power Supply

Both regulated and unregulated power supplies can be used to supply the driver. However, unregulated power supplies are preferred due to their ability to withstand current surge. If regulated power supplies (such as most switching supplies.) are indeed used, it is important to have large current output rating to avoid problems like current clamp, for example using 4A supply for 3A motor-driver operation. On the other hand, if unregulated supply is used, one may use a power supply of lower current rating than that of motor (typically 50%~70% of motor current). The reason is that the driver draws current from the power supply capacitor of the unregulated supply only during the ON duration of the PWM cycle, but not during the OFF duration. Therefore, the average current withdrawn from power supply is considerably less than motor current. For example, two 3A motors can be well supplied by one power supply of 4A rating.

◆ Multiple Drivers

It is recommended to have multiple drivers to share one power supply to reduce cost, if the supply has enough capacity. To avoid cross interference, DO NOT daisy-chain the power supply input pins of the drivers. (Instead, please connect them to power supply separately.)

◆ Selecting Supply Voltage

The power MOSFETS inside the MC860H can actually operate within +24 ~ +90VDC or 18~80VAC, including power input fluctuation and back EMF voltage generated by motor coils during motor shaft deceleration. Higher supply voltage can increase motor torque at higher speeds, thus helpful for avoiding losing steps. However, higher voltage may cause bigger motor vibration at lower speed, and it may also cause over-voltage protection or even driver damage. Therefore, it is suggested to choose only sufficiently high supply voltage for intended applications, and it is suggested to use power supplies with theoretical output voltage of +20 ~ +50VDC or 18~80VAC, leaving room for power fluctuation and back-EMF.

7. Selecting Microstep Resolution and Output Current

This driver uses an 8-bit DIP switch to set microstep resolution, and motor operating current, as shown below:

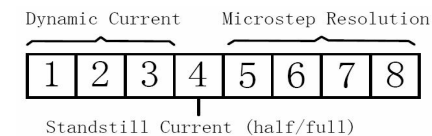

◆ Microstep Resolution Selection

Microstep resolution is set by SW5, 6, 7, 8 of the DIP switch as shown in the following table:

Microstep	Steps/rev.(for 1.8° motor)	SW5	SW6	SW7	SW8
2	400	ON	ON	ON	ON
4	800	OFF	ON	ON	ON
8	1600	ON	OFF	ON	ON
16	3200	OFF	OFF	ON	ON
32	6400	ON	ON	OFF	ON
64	12800	ON	OFF	OFF	ON
128	25600	OFF	OFF	OFF	ON
256	51200	OFF	OFF	OFF	ON
5	1000	ON	ON	ON	OFF
10	2000	OFF	ON	ON	OFF
20	4000	ON	OFF	ON	OFF
25	5000	OFF	OFF	ON	OFF
40	8000	ON	ON	OFF	OFF
50	10000	OFF	ON	OFF	OFF
100	20000	ON	OFF	OFF	OFF
200	40000	OFF	OFF	OFF	OFF

◆ Current Settings

For a given motor, higher driver current will make the motor to output more torque, but at the same time causes more heating in the motor and driver. Therefore, output current is generally set to be such that the motor will not overheat for long time operation. Since parallel and serial connections of motor coils will significantly change resulting inductance and resistance, it is therefore important to set driver output current depending on motor phase current, motor leads and connection methods. Phase current

rating supplied by motor manufacturer is important in selecting driver current, however the selection also depends on leads and connections.

The first three bits (SW1, 2, 3) of the DIP switch are used to set the dynamic current.

Select a setting closest to your motor's required current.

Peak Current	RMS Current	SW1	SW2	SW3
2.40A	2.00A	ON	ON	ON
3.08A	2.57A	OFF	ON	ON
3.77A	3.14A	ON	OFF	ON
4.45A	3.71A	OFF	OFF	ON
5.14A	4.28A	ON	ON	OFF
5.83A	4.86A	OFF	ON	OFF
6.52A	5.43A	ON	OFF	OFF
7.20A	6.00A	OFF	OFF	OFF

Notes: Due to motor inductance, the actual current in the coil may be smaller than the dynamic current setting, particularly under high speed condition.

◆ Standstill current setting

SW4 is used for this purpose. OFF meaning that the standstill current is set to be half of the selected dynamic current, and ON meaning that standstill current is set to be the same as the selected dynamic current.

The current automatically reduced to 60% of the selected dynamic current one second after the last pulse. Theoretically, this will reduce motor heating to 36% (due to $P=I^2 \cdot R$) of the original value. If the application needs a different standstill current, please contact Lichuan.

8. Wiring Notes

- In order to improve anti-interference performance of the Driver, it is recommended to use twisted pair shield cable.
- To prevent noise incurred in PUL/DIR signal, pulse/direction signal wires and motor wires should not be tied up together. It is better to separate them by at least 10 cm, otherwise the disturbing signals generated by motor will easily disturb pulse direction signals, causing motor position error, system instability and other failures.
- If a power supply serves several Drivers, separately connecting the Drivers is recommended instead of daisy-chaining.
- It is prohibited to pull and plug connector P2 while the Driver is powered ON, because there is high current flowing through motor coils (even when motor is at standstill). Pulling or plugging connector P2 with power on will cause extremely high back-EMF voltage surge, which may damage the Driver.

9. Protection Functions

To improve reliability, the Driver incorporates some built-in protection functions. The MC556 uses one RED LED to indicate what protection has been activated. The periodic time of RED is 3s (seconds), and how many times the RED turns on indicates what protection has been activated. Because only one protection can be displayed by RED LED, so the Driver will decide what error to display according to their priorities. See the following Protection Indications table for displaying priorities.

◆ Over-current Protection

Over-current protection will be activated when continuous current exceeds 16A or in case of shortcircuit between motor coils or between motor coil and ground, and RED LED will turn on once within each periodic time (3 s).

◆ Over-voltage Protection

When power supply voltage exceeds 90 ± 1 VDC or 80 ± 1 VAC, protection will be activated and RED LED will turn on twice within each periodic time (3 s).

◆ Phase Error Protection

Motor power lines wrong & not connected will activate this protection. RED LED will turn on four times within each periodic time (3 s).

Attention: When above protections are active, the motor shaft will be free or the LED will turn red. Reset the Driver by repowering it to make it function properly after removing above problems. Since there is no protection against power leads (+, -) reversal, it is critical to make sure that power supply leads are correctly connected to Driver. Otherwise, the Driver will be damaged instantly.

10. Frequently Asked Questions

In the event that your Driver doesn't operate properly, the first step is to identify whether the problem is electrical or mechanical in nature. The next step is to isolate the system component that is causing the problem. As part of this process you may have to disconnect the individual components that make up your system and verify that they operate independently. It is important to document each step in the troubleshooting process. You may need this documentation to refer back to at a

later date, and these details will greatly assist our Technical Support staff in determining the problem should you need assistance.

Many of the problems that affect motion control systems can be traced to electrical noise, controller software errors, or mistake in wiring.

◆ **Problem Symptoms and Possible Causes**

Symptoms	Possible Problems
Motor is not rotating	Microstep resolution setting is wrong DIP switch current setting is wrong Fault condition exists
Motor rotates in the wrong direction	Motor phases may be connected in reverse
The Driver in fault	DIP switch current setting is wrong Something wrong with motor coil Control signal is too weak
Erratic motor motion	Control signal is too weak Control signal is interfered Wrong motor connection Something wrong with motor coil Current setting is too small, losing steps Current setting is too small
Motor stalls during acceleration	Motor is undersized for the application Acceleration is set too high Power supply voltage too low
Excessive motor and Driver heating	Inadequate heat sinking / cooling Automatic current reduction function not being utilized Current is set too high